

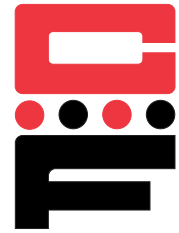

Self-Clinching Slide-Top Standoffs

Series CFSKC



Continued from previous page.

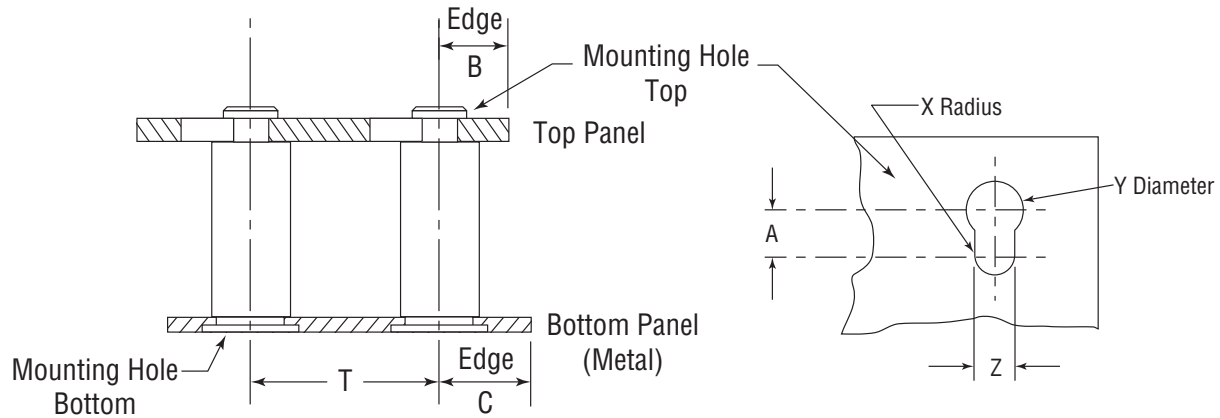

Installation & Performance Data

INCH (in.)	Bottom Panel				Top Panel						
	Bottom Mounting Hole +.003 -.000	Min.	C Min.	Location Tolerance T Max.	Top Mounting Hole				Material	Thickness Range	B Min.
					X Nom.	Y ± .003	Z ± .003	A Min.			
CFSKC	.213	.040	.260	± .005	.059	.197	.118	.148	PC Board or Metal	.057 - .064	.160

Installation & Performance Data

METRIC (mm)	Bottom Panel				Top Panel						
	Bottom Mounting Hole +.08 -.00	Min.	C Min.	Location Tolerance T Max.	Top Mounting Hole				Material	Thickness Range	B Min.
					X Nom.	Y ± .08	Z ± .08	A Min.			
CFSKC	5.4	1.0	6.6	± .13	1.5	5.0	3.0	3.75	PC Board or Metal	1.45 - 1.62	4.1